

Fine Pitch LED Display For Indoor Use



LED display cabinets use all-in-one die-casting aluminium cabinet. Fully support front service. All connectors use customized interfaces and components are highly integrated. No cable design. Big load but low power consumption. Can be easily assembled and disassembled, it is user friendly. The built-in hidden type bearing bracket makes the installation more convenient and practical.

✓ Two- Sizes, Assembly At Will

LED cabinet 600x337mm and 300x337mm can be combined together to make a videowall, which provide more choices for customers. Support horizontal and vertical orientation assembly of two kinds of cabinets. One cabinet can be cut to fit more installation requirements and reduce the costs of projects.

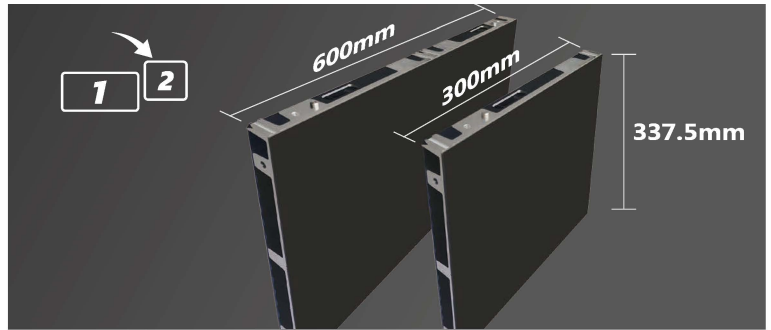

✓ High Precision And Flatness

Aluminium case is produced by high precision CNC machine, it light-weight, strong and anti-erosion. The flatness pins in the aluminium case control the tolerance within 0.05mm. The overall flatness of the led screen brings the best visual effect to viewers.

LED screen tube size 600x600mm

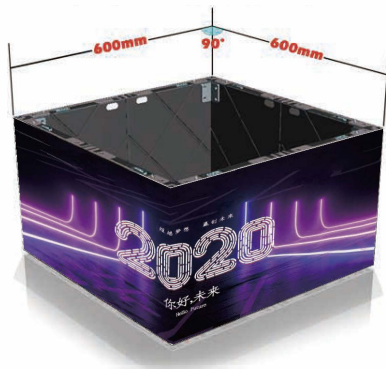

Curved LED screen 90° to 180° adjustable

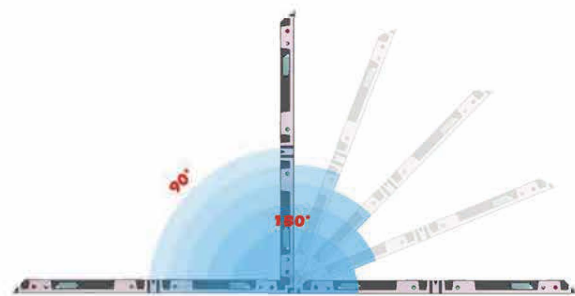

✓ Perfectly Fit Different Kinds Of Curves, Create Surrounded Visual Experience

Seamless splicing LED screen can Break the limits of size, space and structure, perfectly fit different curves of architectures and create surrounded visual experience. More importantly, it cut the costs for displaying information and images in such a vivid way.



✓ Ultra Thin And Light-weight

The thickness of the cabinet is only 32mm, it has high stability and supports both front and rear installation. It can be installed closely to the wall, so there is no need to reserve a rear maintenance access and save more space for the limited indoor environment.

Compared with the standard products, this cabinet is 40% lighter. It will not only reduce the freight cost, but also make installation easier and more stable.

✓ Front Maintenance Design

Completely front-maintenance is a very necessary engineering application requirement for fine pitch LED display. In this way, the installation thickness can be greatly guaranteed.

No need for rear maintenance access, which can better protect the product, prevent dust accumulation and electronic components/PCB boards damage.

Using vacuum tools to quickly replace modules to guarantee maintenance efficiency.

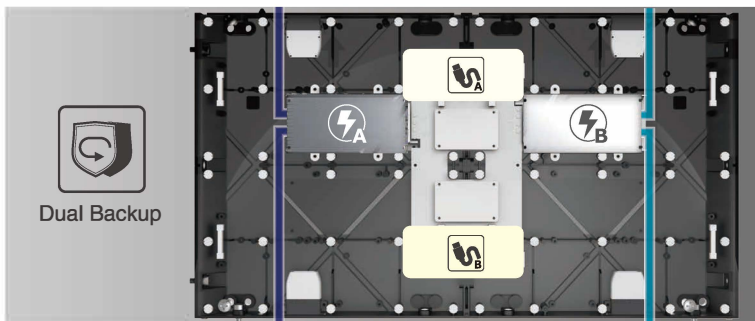

✓ Dual Backup

LED display adopts dual backup design. Whenever there is interruption of data transmitting the backup data will be automatically activated to ensure the normal function of the LED display.

✓ Noiseless, More Energy-saving

Aluminium back plate with effectively heat dissipation, fanless LED cabinet, noiseless. Zero noise operation is more friendly to your life.

At the same time, it also reduces the power consumption of the display, effectively saving the running cost of the display.

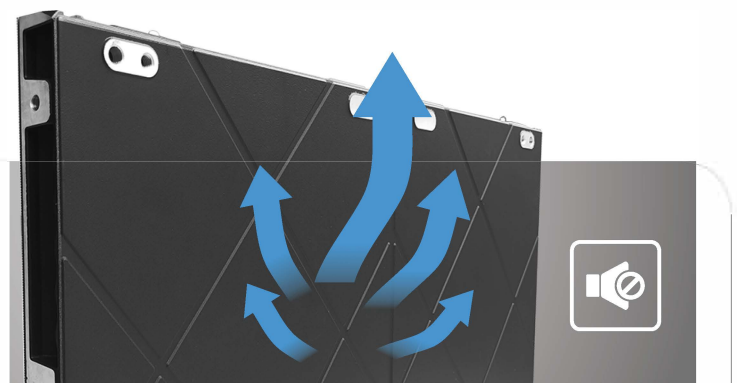

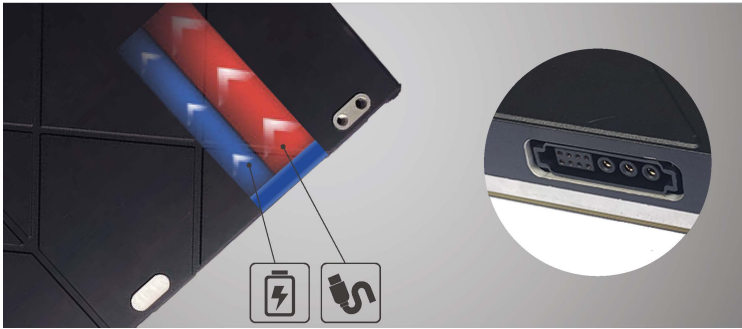

✓ Hidden Fast Interface

Power and signal cables are hidden inside of LED cabinet, to avoid the accidental damages of the cables and keep the entire led screen neat.

Use aviation connectors, data and power integrated into one cable, one step to finish the data and power connection.

✓ Wall-mount Installation, Suitable For A Variety Of Applications

LED cabinet can be fixed to wall with bolts or with wall-mount-bracket.

A slim led screen can fully make use of the limited indoor space and suitable for a variety of indoor applications.

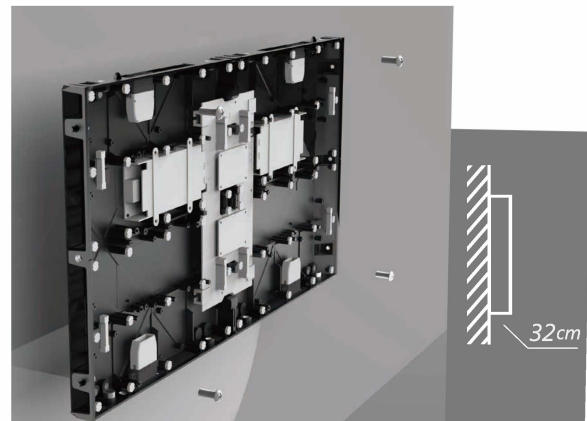

✓ Up/Down Link

Two cabinets use positioning pins and two Coaxial screws for seamless alignment.

✓ Left/right Link

Two cabinets use positioning pins and two Coaxial screws for seamless alignment.



✓ **High Gray Scale Even At Low Brightness, Display every content vividly**

16bit processing technology, every part of led screen at any brightness level has good performance in gray scale. Every detail of the content can be displayed vividly.



✓ **160° Viewing Angle, Perfect Display Image**

LED screen has 160° wide viewing angle, clear image and true color, it is popular than the traditional LCD and DLP which has limited viewing angle and loss of colors.



Wide viewing angle

✓ **Ultra-high Refresh Rate Highlights Exciting Moment**

Refresh rate reach 3840Hz, support Fast decoding and response. No shaking, lines or moire before digital cameras. Ensure every frame of image is clear and smooth, present the best visual experience.



Examples of Full HD multi- screen configurations by viewing distance

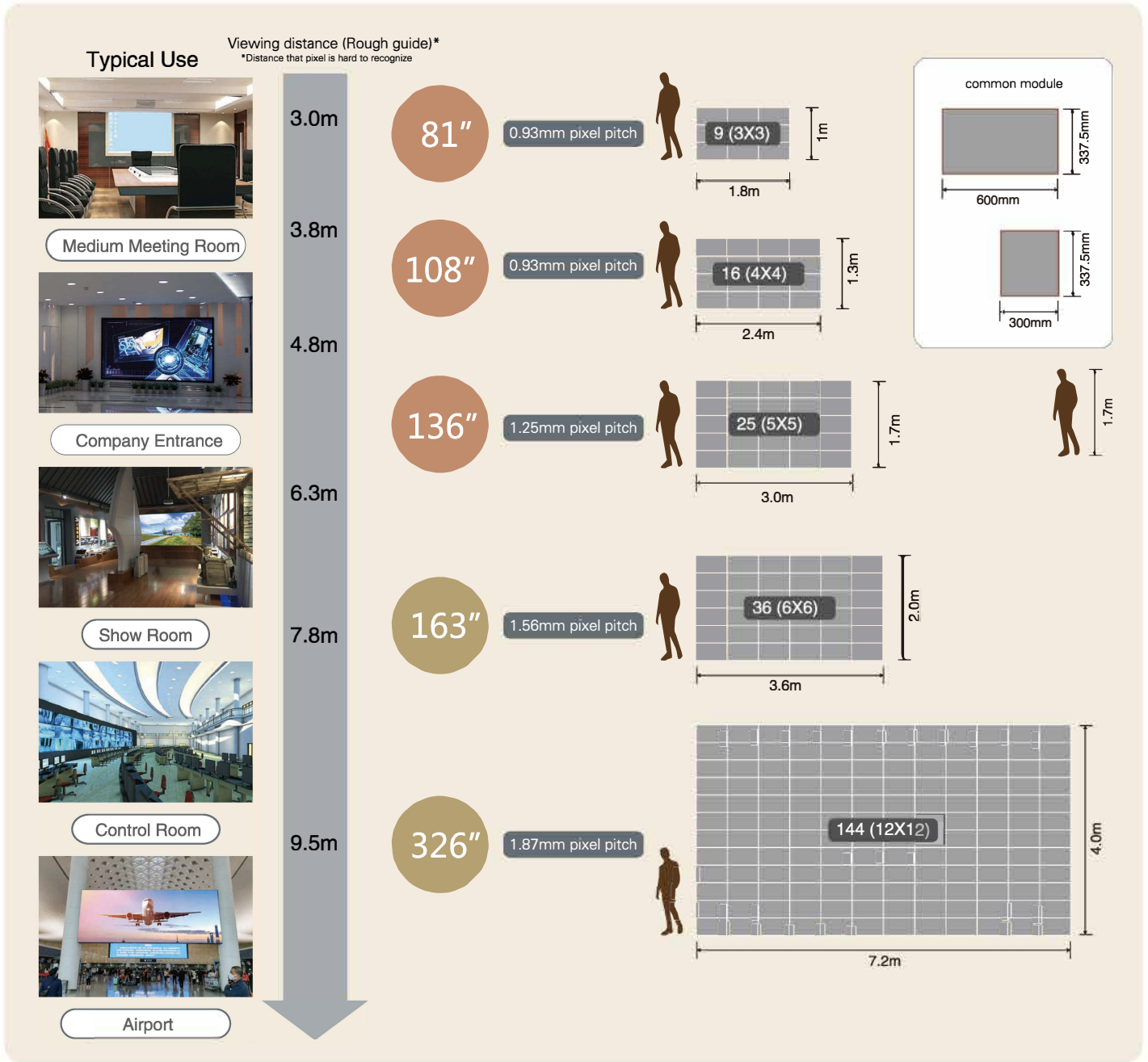

Dimension (mm)

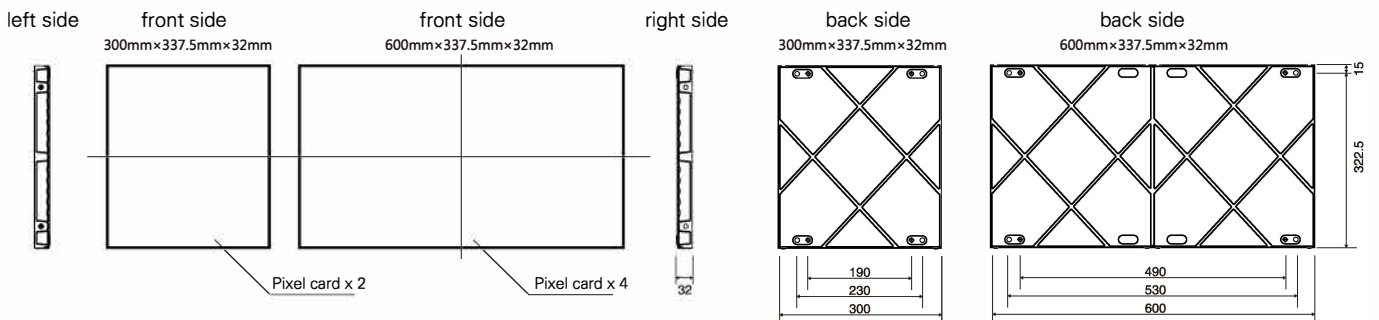

3X3size: 81in, 4X4size: 108in, 5X5size: 136in, 6X6size: 163in....

Product features:



Patented



Seamless Splicing



Ultra-slim



Good Uniformity



Front And Back Installation



Front Service



International Approvals



Fast Assembly



Light-weight



Full Hd

Technical Specifications:

Model Number	0.93mm	1.25mm	1.56mm	1.87mm
Pixel Pitch	0.93 mm	1.25 mm	1.56 mm	1.87 mm
Cabinet resolution	640 x 360 Pixels	480x 270 Pixels	384 x 216 Pixels	320 x 180 Pixels
Brightness (6000K color temperature)	800cd~1500cd/m ²	800cd~1500cd/m ²	800cd~1200cd/m ²	600cd~1000cd/m ²
Pixel density	113778 dots/m ²	640000 dots/m ²	409600 dots/m ²	284444 dots/m ²
Pixels constitution	3in1 (1R1G1B)			
Cabinet weight	4.3kg			
Cabinet dimensions	600mm×337.5mm×32mm / 300mm×337.5mm×32mm			
Gray scale	16 bit			
Contrast ratio	3500:1			
Peak consumption	≤600W/m ²			
Average consumption	100W/m ² ~ 300W/m ²			
screen color temperature	2000~9500K Adjustable			
Module flatness	≤0.1mm			
Horizontal viewing angle / Vertical viewing angle	160° /140°			
Refresh rate	High refresh rate ≥3000Hz			
Frame rate	50~60Hz			
Working voltage	AC: 95V~240V			
Power supply mode	DC / AC Power supply (Options)			
Ingress protection rating	IP41			
LED life-time	100,000h			
Viewing distance	≤0.1mm			
screen temperature raise (Under normal use)	≤20Celsius degree			
Pixel calibration	Brightness and chromatic pixel calibrations			
Control method	Synchronous / Asynchronous control			
Driving method	Constant current drive			
Cabinet material	Die-casting aluminium case			
Heat dissipation method	Electronics passive cooling, entire unit air-flow cooling			
MTBF	≥10000 Hours			
Power-backup	Dual backup power supply (optional)			
Signal backup	Dual backup signal (optional)			
Transmission distance	CAT5 ,Optic fiber cables when exceed 100 meters			
Working temperature/humidity	-10~+60°C / 10%~90%RH, No condensation			
Installation way	Mount-bracket / Wall-mount / Frame mount			
Maintenance	Front service			

Remarks: Above parameters subject to change without prior notifications

Basic system configuration example

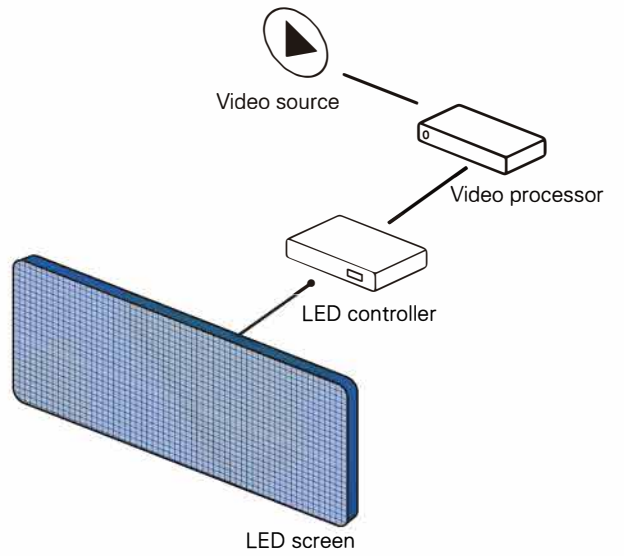
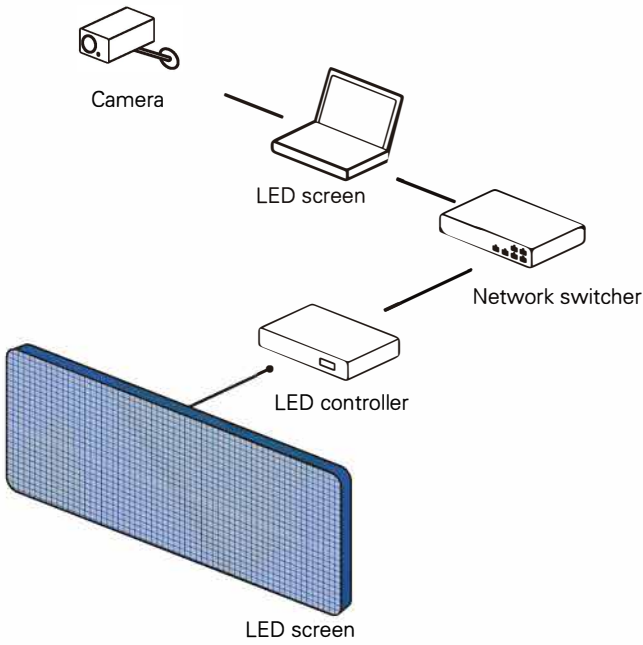
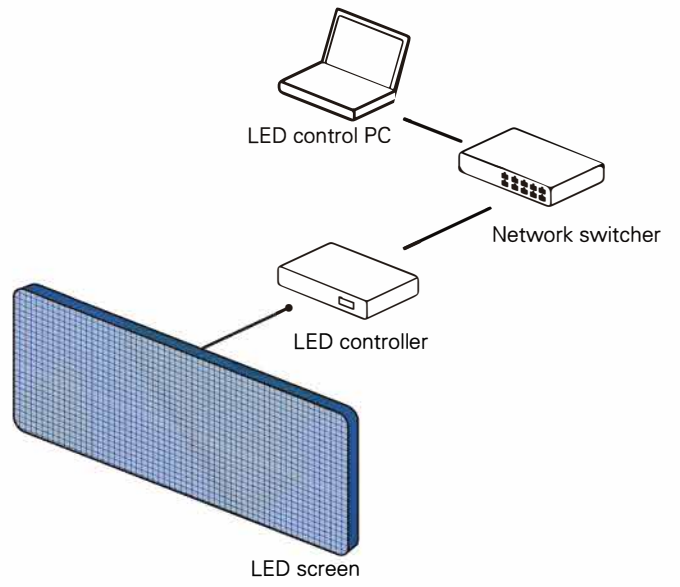
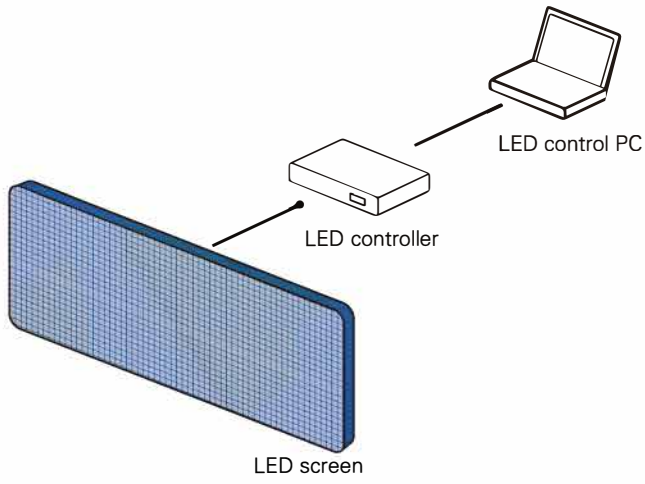

LED controller and LED screen maximum distance 100 meters, use fiber optic cables if exceed this distance.

Remarks: Above parameters subject to change without prior notifications